



Product Specifications - LED Highbay

Technical Specifications

- Die-cast aluminum housing for LED driver and chips with MV Hi fins as heat sink with ribbed polycarbonate reflector
- LED: Philips
- 120 – 277 volt operation
- CRI: 80
- Color temperature: 5000K CW
- Power factor: 95%+
- L70 design life (50,000 hours)
- Operating temperature: -4°F to 140°F
- Damp location listed



Applications

Ideal for general warehouse lighting, loading docks, storage areas, supermarkets. The polycarbonate lens provide 360° illumination combined with crisp, directional, bright 5000K light that will make merchandise clearly visible and eye-catching.

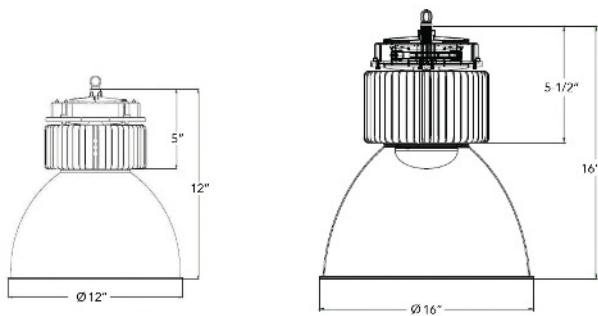

Product Name	Chip	Wattage	Voltage	Lumens	Color Temp	Diameter & Height
LHB-50-CW	Philips	50W	120/277V AC	4500	CW 5000K	12" x 12"
LHB-100-CW	Philips	100W	120/277V AC	9000	CW 5000K	16" x 16"
LHB-150-CW	Philips	150W	120/277V AC	13000	CW 5000K	16" x 16"
LHB-200-CW	Philips	220W	120/277V AC	18000	CW 5000K	16" x 16"